

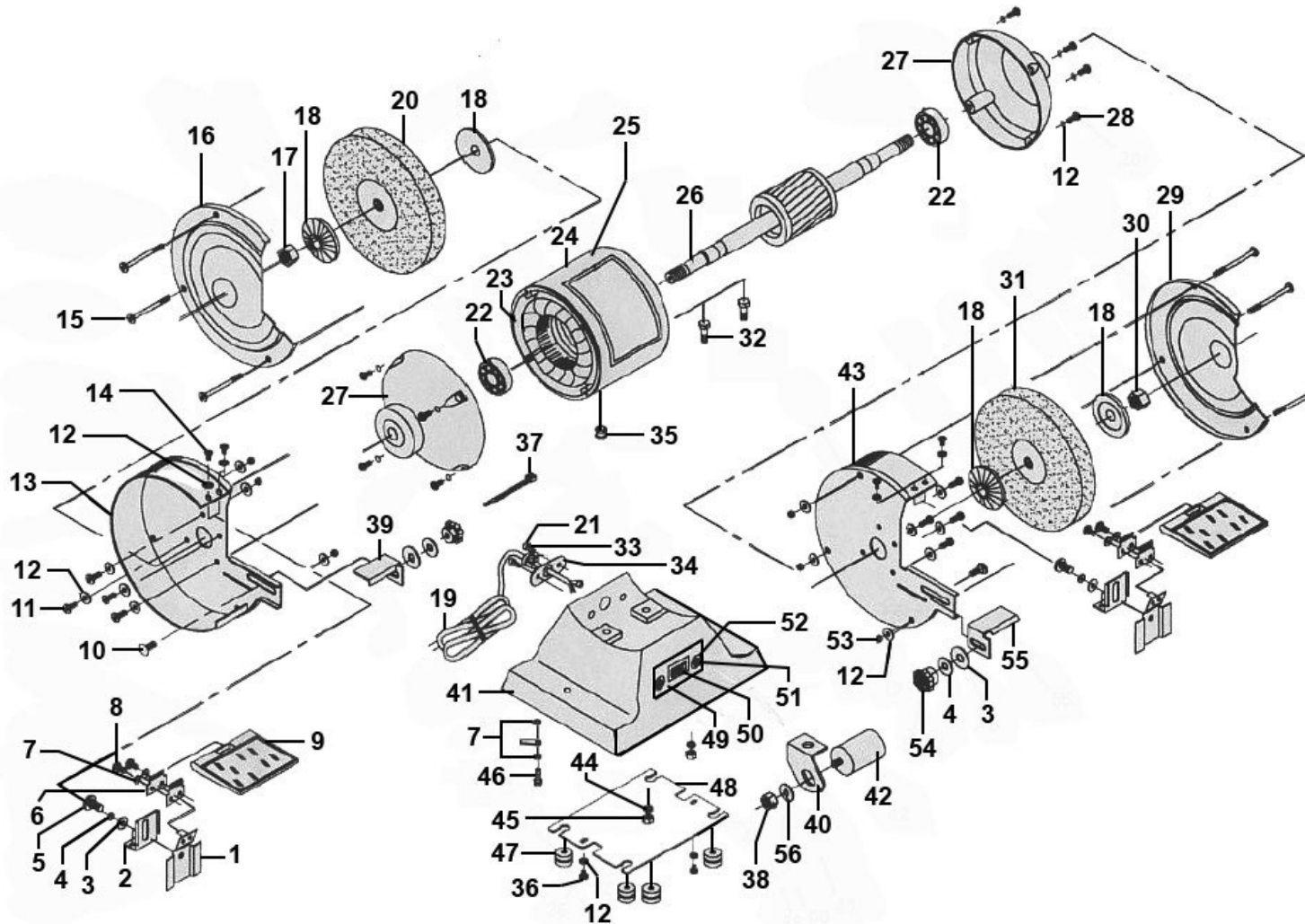

Parts Information:
Bench Grinder Ø150mm 370W/230V
Model No: BG150XL/96.V2



NOTE: It is our policy to continually improve products and as such we reserve the right to alter data, specifications and component parts without prior notice.

There may be alternative versions of this product, please contact us should you require this information.

IMPORTANT: No liability is accepted for incorrect use of product. Spare parts must be fitted by a competent person

WARRANTY: Guarantee is 12 months from purchase date, proof of which will be required for any claim.

Sealey Group, Kempson Way, Suffolk Business Park, Bury St Edmunds, Suffolk. IP32 7AR



01284 757500



01284 703534



sales@sealey.co.uk



www.sealey.co.uk



Parts Information:
Bench Grinder Ø150mm 370W/230V
Model No: BG150XL/96.V2

Item	Part No.	Description
1	BG150XL96V201	Eyeshield bracket
2	BG150XL96V202	Bracket support
3	RW619.S	Repair Washer M6 X 19 Zinc
4	FWM6.S	Flat Washer M6 Zinc
5	MSP610.S	Machine Screw Pan Head Phillips M6 X 10mm
6	BG150XL96V206	Eyeshield Holder
7	FWM4.S	Flat Washer M4
8	MSP46.S	Machine Screw Pan Head Phillips M4 X 6mm
9	BG150XL96V209	Eyeshield (Clear Plastic Part Only)
10	CBN616.S	Coach Bolt M6 x 16mm
11	MSP510.SB	Machine Screw Pan Head Phillips M5 x 10mm Black
12	FWM5.S	Flat Washer M5 Zinc
13	BG150XL96V213	Left Wheel Guard
14	MSP58.S	Machine Screw Pan Head Phillips M5 X 8mm
15	MSP560.S	Machine Screw Pan Head Phillips M5 X 60mm
16	BG150XL96V216	Left Cover, Wheel Guard
17	BG150XL96V217	Nut M12 Left
18	BG150XL96V218	Wheel Flange
19	BG150XL96V219	Cord & Plug
20	BG150/16	Grinding Stone Ø150 x 20mm 32(13)mm Bore A36Q Coarse
21	MSP58.S	Machine Screw Pan Head Phillips M5 X 8mm
22	B/6202ZZ	Bearing 6202zz
23	BG150XL96V223	Stator
24	BG150XL96V224	Motor Case
25	BG150XL96V225	Label
26	BG150XL96V226	Rotor
27	BG150XL96V227	End Casing
28	MSP516.S	Machine Screw Pan Head Phillips M5 x 16mm
29	BG150XL96V229	Right Cover, Wheel Guard

Item	Part No.	Description
30	SN12.S	Steel Nut M12 Zinc
31	BG150/15	Grinding Stone Ø150 x 20mm 32(13)mm Bore A60P Fine
32	SS625.S	Hex Head Set Screw M6 X 25 Zinc
33	BG150XL96V233	Cord Grip
34	BG150XL96V234	Strain Relief
35	BG150XL96V235	Protection Ring
36	MSP510.SB	Machine Screw Pan Head Phillips M5 x 10mm Black
37	BG150XL96V237	Cable Tie
38	SN8.S	Steel Nut M8 Zinc
39	BG150XL/96-08	Tool Rest, Left
40	BG150XL96V240	Capacitor Holder
41	BG150XL96V241	Base
42	BG150XL96V242	Capacitor
43	BG150XL96V243	Right Wheel Guard
44	FWM6.S	Flat Washer M6 Zinc
45	SN6.S	Steel Nut M6 Zinc
46	MSP58.SB	Machine Screw Pan Head Phillips M5 x 8mm Black
47	BG150XL96V247	Rubber Foot
48	BG150XL96V248	Base Plate
49	BG150XL96V249	Label For Rocker Switch
50	BG150XL96V250	Switch, Rocker W/o Fixing Plate - 16A/250V - T105
51	MSP310.S	Machine Screw Pan Head Phillips M3 x 10mm
52	FWM3.S	Flat Washer M3 Zinc
53	SN5.S	Steel Nut M5 Zinc
54	BG150XL/96-TF	Tool Rest Fixing Complete
55	BG150XL/96-40	Tool Rest, Right
56	FWM8.S	FlatFWM8.S Washer M8 Zinc

NOTE: It is our policy to continually improve products and as such we reserve the right to alter data, specifications and component parts without prior notice. There may be alternative versions of this product, please contact us should you require this information.

IMPORTANT: No liability is accepted for incorrect use of product. Spare parts must be fitted by a competent person

WARRANTY: Guarantee is 12 months from purchase date, proof of which will be required for any claim.

Sealey Group, Kempson Way, Suffolk Business Park, Bury St Edmunds, Suffolk. IP32 7AR



01284 757500



01284 703534



sales@sealey.co.uk



www.sealey.co.uk